

SBS BRICK PACK MACHINE

*Excellent flexibility,
wide range of products,
various bag styles.*

Best differentiation
at the point of sale



HIGH FLEXIBILITY IN THE BAG TOP DESIGN

The highlights.

- Best differentiation of your products at the point of sale
- Excellent flexibility – wide range of products, various bag styles, 40 different bag top shapes
- Conveyor filling for break-sensitive products
- High bag quality as replacement for prefabricated bags
- Separately driven work stations for fast format changes
- Maximum machine accessibility due to modular construction
- Security of investment, as it can be extended flexibly
- New modular hygiene design with different bag top shapes
- Intuitive, easily understandable operation, user interface with graphic support in national language

ROVEMA

Passion for packaging



SBS

BRICK PACK MACHINE

Examples for bag top shapes.

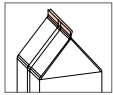

SBS basic forms

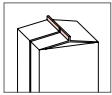

90° folding of the top fin

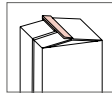

Label as reclosure

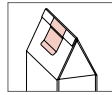

Adhesive tape as reclosure

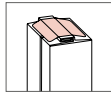

Hot glue

The SBS brick pack machine is a combination of a Form Fill Seal machine with downstream systems for bag and bag closure designs. Thus the bag is designed to meet market requirements, provide extra convenience and impart individual product presentation. You can use the SBS to package a wide range of products. The SBS ensures product-specific handling and economical packaging of lumpy, granulated and powdery products from the food or non-food area – no matter whether cereals, pasta, spices or biscuits.

Benefits and advantages of the SBS.

- Flexibility is one of the outstanding features of the machine. It offers the guarantee of attractive and modern bag design and a secure investment. Pack dimensions can be stored so that the SBS can easily be converted to other format sizes, filling functions or top shapes. Brick packaging, for example, and bags with opening aid and/or reclosing possibility can be produced in one working step. As a matter of course, the SBS is even able to manufacture the attractive Stabilo Seal® bags.
- PC-based ROVEMA P@ck-Control with a user-friendly touch screen and integrated help features. The standard network connection with the ROVEMA service center enables on-line diagnostics and maintenance of the control software.
- The compact design shows a high output on small floor space. Subsequent retrofitting for further packing variety is possible due to the modular system. All functions are installed as single stations and can be adapted for future requirements.
- The SBS can be used as a stand-alone unit or be combined as an integral component of the ROVEMA system technology.

Filling with the Form Fill and Seal machine.

- 1 The pack material track is formed to a tube.
- 2 The pack material tube is sealed lengthwise.
- 3 The side seams are folded, the cross seams formed and the product falls in the bag.
- 4 The bag is separated from the pack material tube.
- 5 The bag is transferred to the cup chain.
- 6 The bag is vibrated.
- 7 Excess air is displaced out of the top seam area.
- 8 The top folds of the bag are shaped.
- 9 The top seam is sealed, excess top fin material is cut off and removed.
- 10 The top fin is folded, compressed and pressed onto the bag.
- 11 The top fin is fastened to the bag.
- 12 The finished bag is discharged.

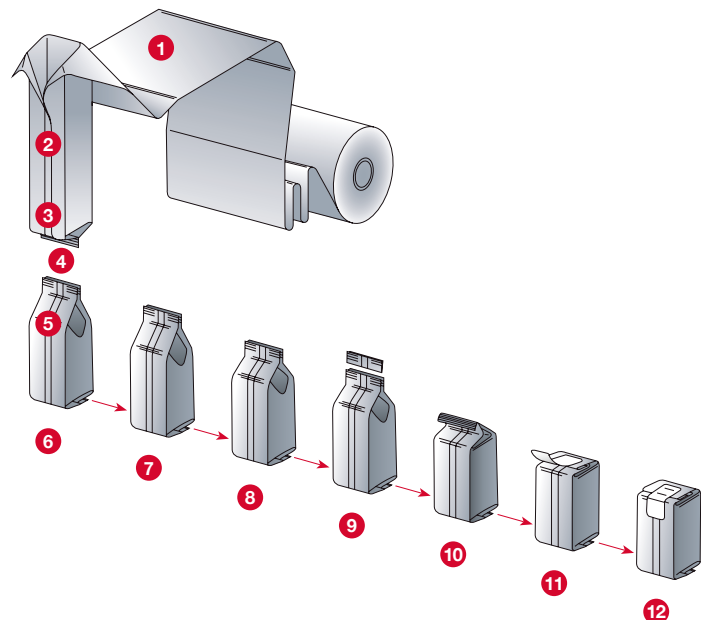

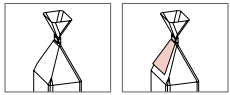

CLIP, also with pendant

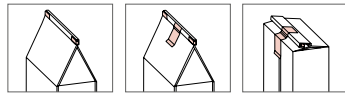

TIN-TIE with fold and press

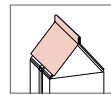

Cap made from cardboard

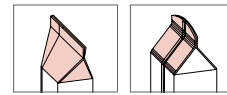

Special top shapes

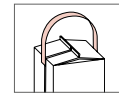

Carry handle

Filling at the conveyor.

- 1 The pack material track is formed to a tube.
- 2 The pack material tube is sealed lengthwise.
- 3 The side seams are folded, the cross seams formed.
- 4 The empty bag is separated from the pack material tube.
- 5 The empty bag is transferred to the cup chain.
- 6 The product is gently dispensed in the bag.
- 7 The bag top is shaped.
- 8 The top seam is sealed, excess top fin material is cut off and removed.
- 9 The finished bag is discharged.

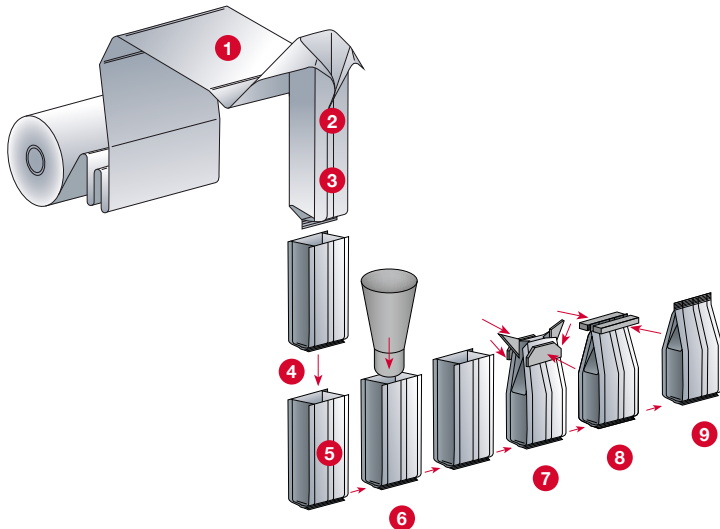

The options.

The modular construction ensures that the SBS will cope with any future packaging requirements, trends in packaging design and new packaging materials. If necessary, the SBS can also operate as a conventional Form Fill and Seal machine.

- Heat sealing, impulse welding or permanently heated jaws
Production of Stabilo Seal® bags
- Integrated or separate filling station providing the most gentle handling for break-sensitive products
- Clip applicator, tin-tie applicator or adhesive tape device to produce reclosable bags
- Labelling of bags on the front and back
- Carry handle device
- Empty bag erection
- Sealing of the bottom seam for optimizing the stability also with low filling weight
- Stainless steel design
- Further options upon request

Technical data.

	SBS 250 Single	SBS 250 Twin
Format area	up to 260 mm*	up to 260 mm*
Output	up to 95 bags/min	up to 160 bags/min
Filling volume	up to 4000 cm ³	up to 4000 cm ³

*Larger formats are available upon request

Subject to technical changes.

Performance data is dependent on product and packaging material.

ROVEMA worldwide

Products & Life Cycle Services



Passion for packaging

Subsidiaries

ROVEMA GmbH
35463 Fernwald
info@rovema.de

ROVEMA France SAS
93360 Neuilly-Plaisance
info@rovema.fr

ROVEMA Benelux bv
4902 TT Oosterhout
sales@rovema.nl

ROVEMA Italia s.r.l.
20026 Novate Milanese (MI)
info@rovema-italia.it

ROVEMA Packaging
Machines Ltd
Gatehouse Close/Aylesbury
sales@rovema.co.uk

ROVEMA Spain and Portugal S.L.
08208 Sabadell/Barcelona
rovema@rovema.es

ROVEMA Makine San. Ve Tic. A.S.
34870 Kartal/Istanbul
info@rovema.com.tr

OOO ROVEMA
196247 St. Petersburg, Russia
info@rovema.ru

ROVEMA Polska Sp. z o.o.
02-672 Warszawa
rovema@rovema.pl

ROVEMA North America Inc.
Norcross, GA 30093
info@rovema-na.com

ROVEMA Latinoamérica S.A.
Panama City
rlinfo@rovema.com

ROVEMA Asia Pacific
Corporation
Makati City/Philippines
info@rovema.com.ph

ROVEMA Affiliates

DL Packaging
www.dlpack.com

Hassia Packaging Pvt Ltd
www.hassiaindia.in

inno-tech
Verpackungsmaschinen GmbH
www.innotech-gmbh.com